

EcoNexus Duo

Operator Instruction Leaflet

IMPORTANT NOTE: ENSURE THAT ALL RELEVANT PERSONNEL READ THESE INSTRUCTIONS PRIOR TO USE

OPENING THE ECONEXUS

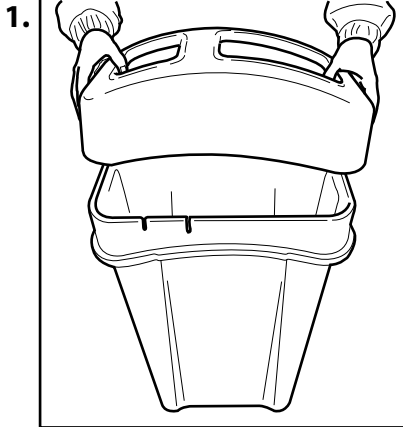

Using the finger lips, lift the lid upwards until it stands upright.

SECURING SACK IN POSITION

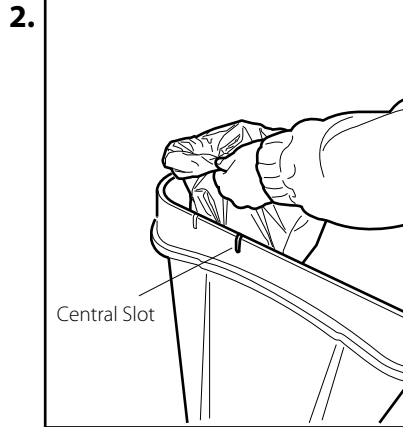

To install sacks, firstly insert into the central slots then stretch over the outer rim of bin.

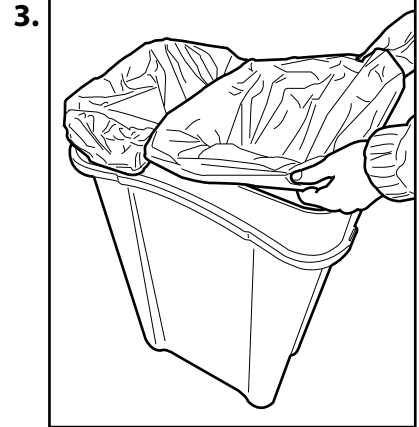

For 50/50 use 2 x **500x1050mm** sacks;
For 70/30 use 1 x **500x1050mm** & 1 x **610x1720mm** sacks.

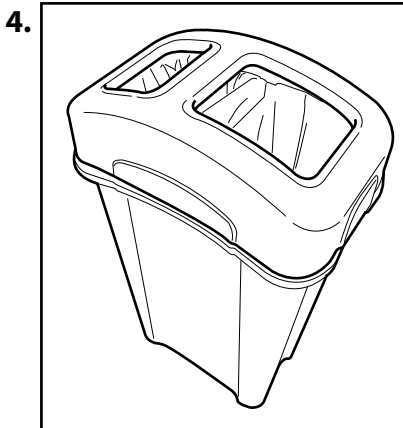

Lower lid to replace, ensuring sacks are neatly secured underneath.

EMPTYING THE ECONEXUS

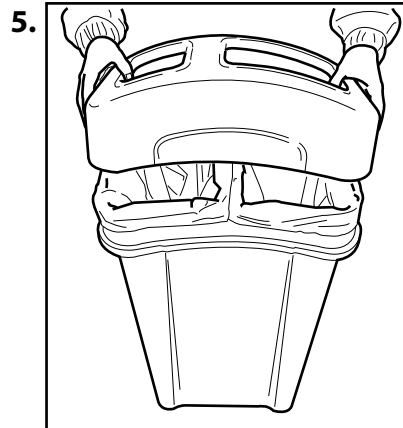

Remove Lid.

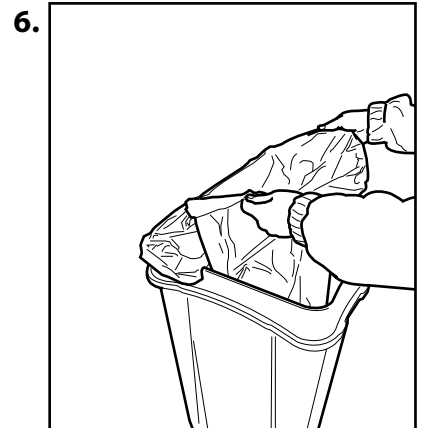

Release each sack individually from the bin rim and lift upwards out of the bin body.

ATTACHING A SIGN KIT

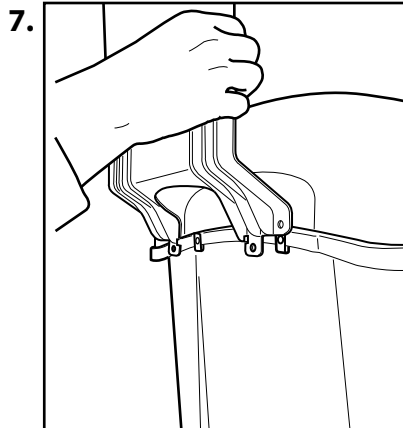

Align the 2 holes with the threaded holes in the metal brackets attached to the bin rear. **Notes:** Do not place sign holder into cutout slots on bin rim. Sign can only be fitted at the rear of the bin.

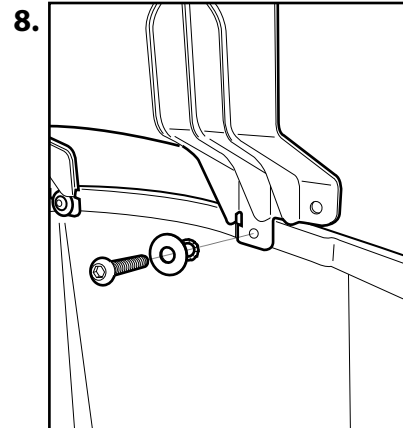

Arrange the included fixtures as follows; Screw, Washer, Locking Washer.

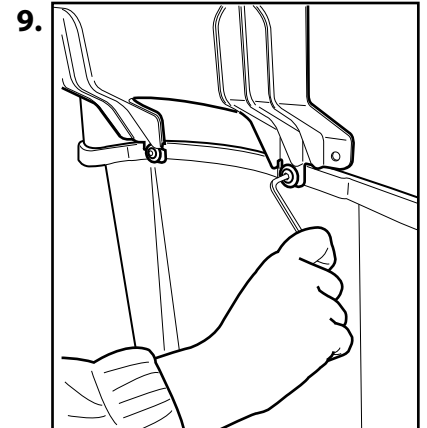

Using an allen key, fasten the sign holder to the bin securely.

EcoNexus Duo

INSERTING A4 SIGN

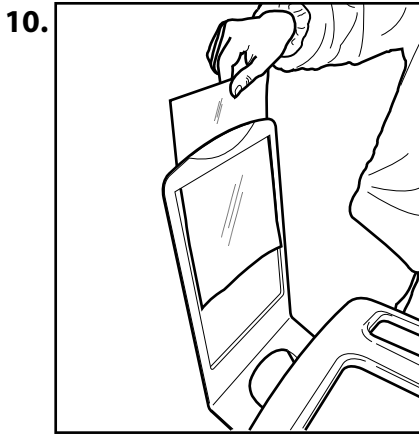

Place A4 sign behind clear polycarbonate sheet and slide into sign carrier.

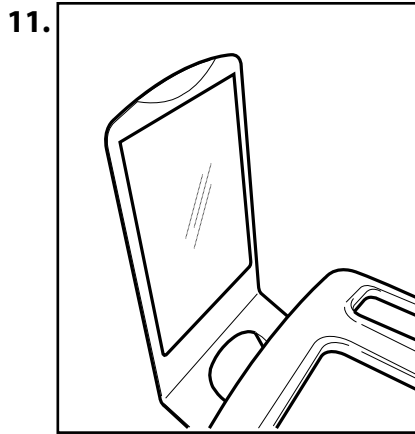

The lugs locate in the holes along the bottom of the carrier to secure the sign.

ATTACHING WHEELS

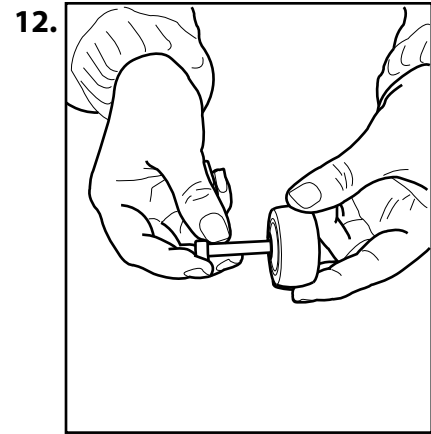

From kit provided, place 1 screw through a wheel.

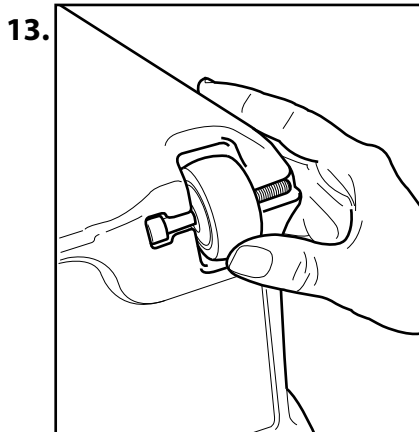

With bin body upside down, click screw and wheel into moulded slot. Repeat with second wheel.

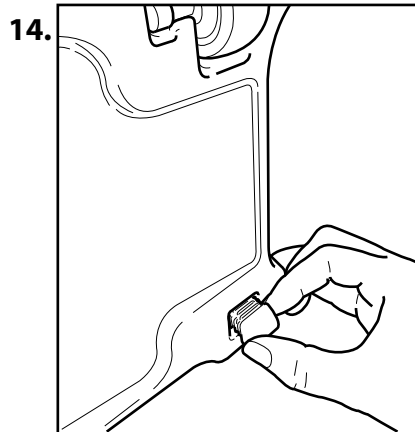

Push both socket caps into the moulded recesses opposite wheels.

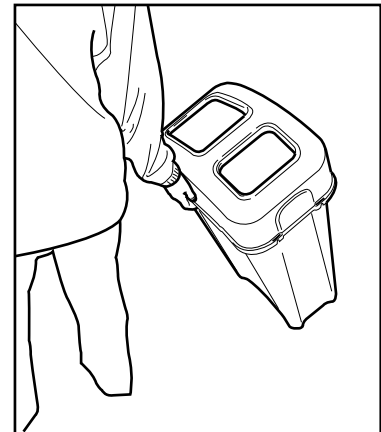

Using lip on body as a handle, tilt bin onto wheels to manoeuvre.